

Overview

truFYX EXT is the world's first Technical Standard Orders (TSO) certified SBAS Global Positioning System (GPS) position source designed specifically for Unmanned Aircraft Systems (UAS) autopilots and Automatic Dependent Surveillance – Broadcast (ADS-B) OUT solutions. The truFYX incorporates the GPS receiver, antenna, barometric altimeter (FL600), and internal heater into a single waterproof enclosure. Simultaneous dual outputs provide TSO high-integrity performance outputs as well as a precision Kalman filtered output.

Reduce your onboard GPS count by leveraging truFYX as the primary position source to your autopilot and ADS-B solution.

TSO Certification Pending

TSO-C145e, Class Beta-1 GPS provides for:

- Primary position source for ADS-B surveillance
- Primary position source for domestic en route and terminal navigation
- Integrity in the absence of the SBAS signal through the use of Fault Detection and Exclusion (FDE)
- Enhanced accuracy with processing of optional ionospheric corrections
- Meets worldwide requirements for controlled airspace access.

Conformity

Radio Technical Commission for Aeronautics (RTCA):

- DO-229E Class Beta-1
- DO-178C Level C
- DO-254 Level C
- DO-160G

Technical Specification

Specification	Value
Product Identifier	UAX-90040-01
GPS Position Source P/N	UAV-1002809-001
Position Source	
GPS L1 C/A with SBAS	12 GPS Channels 3 SBAS Channels
HPA / VPA	5 m / 7 m
Velocity Accuracy	3 m/s
Time Accuracy	30 ns
Update Rate	5 Hz
SIL/SDA	3/2
Sensitivity	
Acquisition	-148 dBm
Tracking	-167 dBm
Electrical Characteristics	
Input Voltage / Power	5.5-31 V / 0.5 W
Mechanical Characteristics	
Size	55.85 x 46.85 x 8.21 mm
Weight	38 grams
Interfaces	
RS-232	115200 bps
Protocol	NMEA 0183 + RAIM, or MAVLink
Time Pulse	RS-232, 1 pps

DISTRIBUTOR		☎ +1 503.434.6845 ☎ +1 503.217.6080 ✉ customerservice@nwuav.com www.nwuav.com
Northwest UAV <small>A GLOBAL COMPANY</small>		
11160 SW Durham Lane, Suite 1 McMinnville, OR 97128 USA		

Federal Aviation Administration (FAA):

- TSO-C145e Class Beta-1 (Pending)

Electrical

Color	Signal
BLACK	Aircraft Ground
RED	Aircraft Power
GRAY	NMEA RS-232 TXD
ORANGE	NMEA RS-232 RXD
WHITE	PPS Time Pulse

Protocol

NMEA	Sentence
GPRMC	GPS Data
GPGGA	Fix Data
GPGSA	DOP and active satellites
GPGSV	Satellites in View
GPGLL	Position and Time
GPVTG	Track and Ground Speed
GPZDA	Time and Date
RAIM	Protection Limits and Figures of Merit
PUAVVV	Vertical Velocity

Environmental

Condition	DO-160G	Category
Temperature	4.0	B2 (-60C with internal heater)
Temperature Variation	5.0	A
Humidity	6.0	A
Operational Shock	7.0	B
Vibration	8.0	S (Curve M) Zone 2 – Type 5
Waterproofness	10.0	R
Magnetic Field	15.0	Y
Power Input	16.0	BX
Voltage Spike	17.0	B
AF Conducted	18.0	B
Induced Signal Susceptibility	19.0	AC
RF Susceptibility	20.0	TT
RF Emissions	21.0	B
Lightning Induced Transient Susceptibility	22.0	A2XXXX
ESD	25.0	A

Mechanical Specification

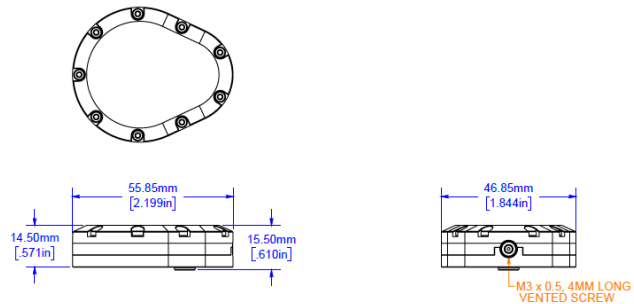

uAvionix reserves the right to alter product, services offerings, specifications, and pricing at any time without notice.

© Copyright 2021 uAvionix, all rights reserved. www.uavionix.com